

# Safety Relay K-ROS



## General

- 4 contacts
- Forced guided contact set
- According to EN 50205, application type A
- Ambient temperature -15 ... +70 °C
- Soldering heat resistance 260 °C/5s
- RoHS compliance

## Connections

- Soldering pins for PCB, pre-soldered with Sn100

## Drive

- Direct current, neutral monostable

## Approvals

- cULus • TÜV

## Standards

- EN 50205 • IEC 61810-1 • UL 508

## Technical Data mechanical

Dimensions L x W x H (in mm)	42 x 16 x 32,2
Shock resistance NO-contact/NC-contact	30/30 g, 11 ms half sinus
Vibration resistance NO-contact/NC-contact	5/5 g, 10 - 55 Hz
Operating time NC-contact, contact opens	typical 9 ms
Operating time NO-contact, contact closes	typical 12 ms
Releasing time NO-contact, contact opens	typical 5 ms
Releasing time NC-contact, contact closes	typical 8 ms
Electrical service life (without load)	>10 <sup>7</sup> cycles
Weight	35 g

## Technical Data electrical

Max. switching capacity	AC 1.840 VA, DC *W
Max. switching voltage	AC 230/240 V, DC *W
Max. switching current NO-contact	8 A
Constant current I <sub>th</sub>	8 A
Constant current I <sub>th2</sub> at the same time over 2 contacts	5,6 A
Constant current I <sub>th2</sub> at the same time over 3 contacts	4,6 A
Switching capacity	AC-15 230/240 V      I <sub>e</sub> = 4 A DC-13 24 V              I <sub>e</sub> = 1,2 A
Electrical service life (with nominal load)	>10 <sup>5</sup> cycles
Short-circuit capacity 1.000 A/AC 230 V	10 A gL/gG-fuse
* see DC switching capacity	

## Insulation

Over voltage category (Ü) III	B-I = Basic insulation
Degree of pollution (V) 2	V-I = Re-inforced (double) insulation
Insulating material group II	

Insulation between	Nominal voltage network system		Air-/creeping distance <sup>e</sup>	Test voltage 50 Hz/60s
	AC 120/240 V	AC 230/400 V		
Contact - Contact	V-I	B-I	> 3 mm	AC 2.500 V
Contactset - Drive	V-I	B-I	> 3 mm	AC 2.500 V

## Dimensions

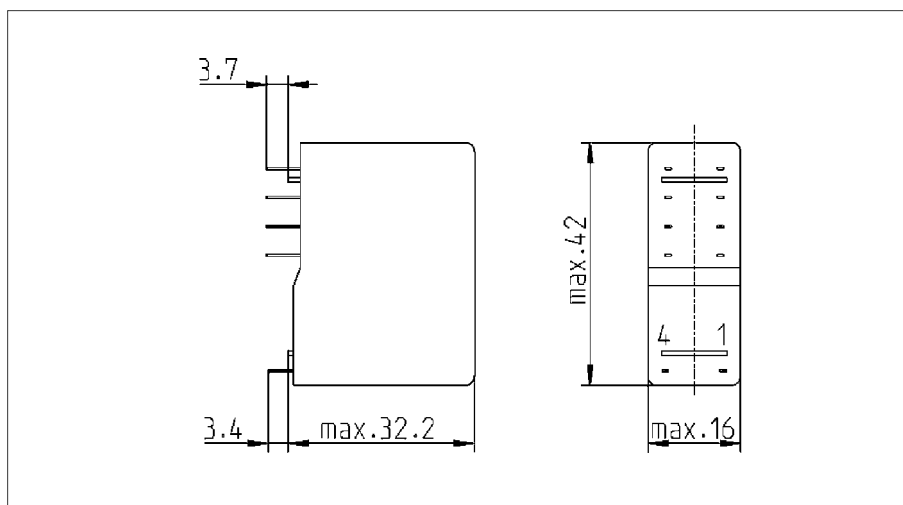

# Safety Relay K-ROS

## Type key

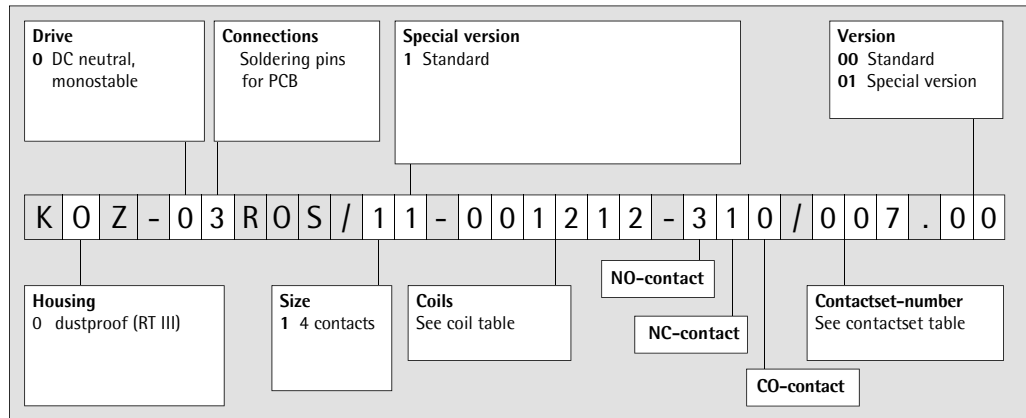

## Contactset table

Contact material AgCdO since 2018 no longer available!

Number of contacts NO/NC/CO-contacts	AgCdO	AgNi * + 0,2 µm Au	AgNi * + 10 µm Au	AgSnO <sub>2</sub> + 0,2 µm Au	AgSnO <sub>2</sub> + 2 µm A	Contact material
<b>220</b>	001	002	003	004	009	Contactset Number
<b>310</b>	005	006	007	008	01	

\* For new projects on request

All values at ambient temperature  $T_u = 20\text{ °C}$

## Coil table

Coil-No.	Resistance R/Ω	Resistance- tolerance ±	$U_1/V$	$U_2/V$	$U_3/V$	$U_{rück}/V$	Printing $U_{nom}/V$
1124	25	5%	3,4	7,7	8	0,2	6
1016	155	8%	8,7	18,9	19	0,5	12
1212	625	7%	17,5	38,2	39	1,0	24
1208	2.100	7%	31,5	69,8	70	1,7	48
1306	4.000	9%	45,6	95,9	98	2,5	60
1204	11.000	11%	73,7	157,9	156	3,9	110
1096	66.000	16%	197,0	379,1	382	9,5	250

$U_1$ : Minimum operating voltage with consideration of coil self heating  
 $U_2$ : Thermal restricted maximum coil voltage  
 $U_3$ : Maximum admissible coil voltage to realize a contact gap of > 0.5 mm also at a contact fault  
 $U_{rück}$ : Releasing voltage

Further coils are possible and available

## Running types

Article-No.	Type key	Printing $U_{nom}$	$U_1/V$	$U_2/V$	$U_3/V$	$U_{rück}/V$
ROS-2500	KOZ-03ROS/11-001212-220/002.00	DC 24 V	17,5	38,2	39	1,0
ROS-2502	KOZ-03ROS/11-001212-310/006.00	DC 24 V	17,5	38,2	39	1,0
ROS-2503	KOZ-03ROS/11-001212-310/005.00	DC 24 V	17,5	38,2	39	1,0
ROS-2504	KOZ-03ROS/11-001016-220/002.00	DC 12 V	8,7	18,9	19	0,5
ROS-2505	KOZ-03ROS/11-001212-220/003.00	DC 24 V	17,5	38,2	39	1,0
ROS-2506	KOZ-03ROS/11-001212-220/004.00	DC 24 V	17,5	38,2	39	1,0
ROS-2508	KOZ-03ROS/11-001212-310/008.00	DC 24 V	17,5	38,2	39	1,0
ROS-2517	KOZ-03ROS/11-001016-310/006.00	DC 12 V	8,7	18,9	19	0,5
ROS-2520	KOZ-03ROS/11-001204-220/009.00	DC 110V	73,7	157,9	156	3,9
ROS-2526	KOZ-03ROS/11-001212-310/010.00	DC 24 V	17,5	38,2	39	1,0
ROS-2542	KOZ-03ROS/11-001204-310/005.00	DC 110 V	73,7	157,9	156	3,9
ROS-2543	KOZ-03ROS/11-001212-220/009.00	DC 24 V	17,5	38,2	39	1,0
ROS-2550	KOZ-03ROS/11-001204-220/004.00	DC 110V	73,7	157,9	156	3,9
ROS-2551	KOZ-03ROS/11-001016-220/009.00	DC 12 V	8,7	18,9	19	0,5
ROS-2553	KOZ-03ROS/11-001208-220/004.00	DC 48 V	31,5	69,8	70	1,7
ROS-2554	KOZ-03ROS/11-001016-220/004.00	DC 12 V	8,7	18,9	19	0,5
ROS-2555	KOZ-03ROS/11-001016-310/008.00	DC 12 V	8,7	18,9	19	0,5
ROS-2558	KOZ-03ROS/11-001208-310/008.00	DC 48 V	31,5	69,8	70	1,7

# Safety Relay K-ROS

**Connection grid**  
View on soldering side

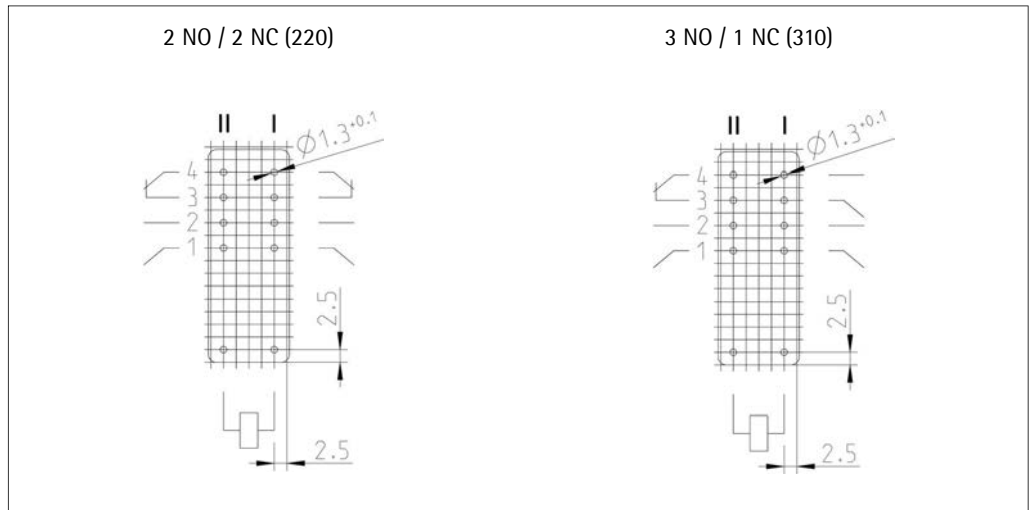

**Diagram**

